

GD50

For free-flowing granules and powders

Industry-leading high-speed packaging solution for free-flowing materials. Ideal for animal feed, pet food, seeds, food raw material, salt, sugar, etc.

Advantages

Servo Drive: 14-axis full servo control for precise, stable operation.

Efficient: Reliable with less maintenance, lower air and energy use.

Output: Highest output per unit area in the industry – ideal for mass production.

Open Design: Easy access for cleaning and maintenance.

Bulk Materials

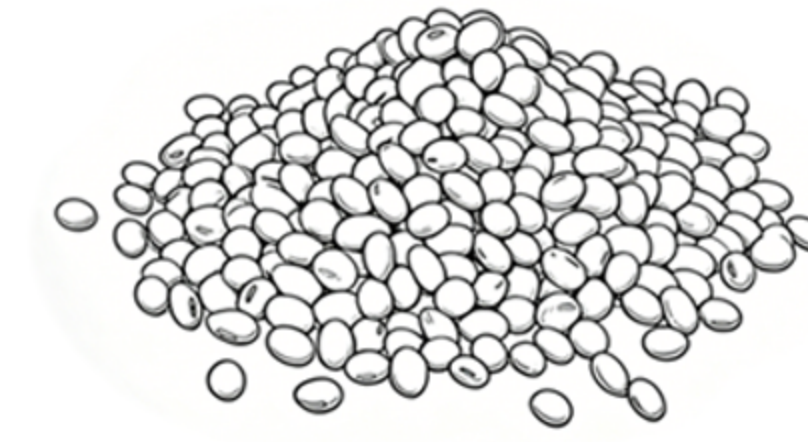

Granules



Powders

Bag Types



Side-gusseted

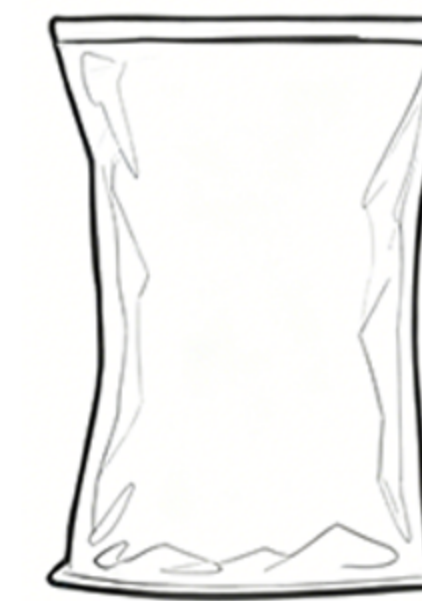

Pillow



Block bottom

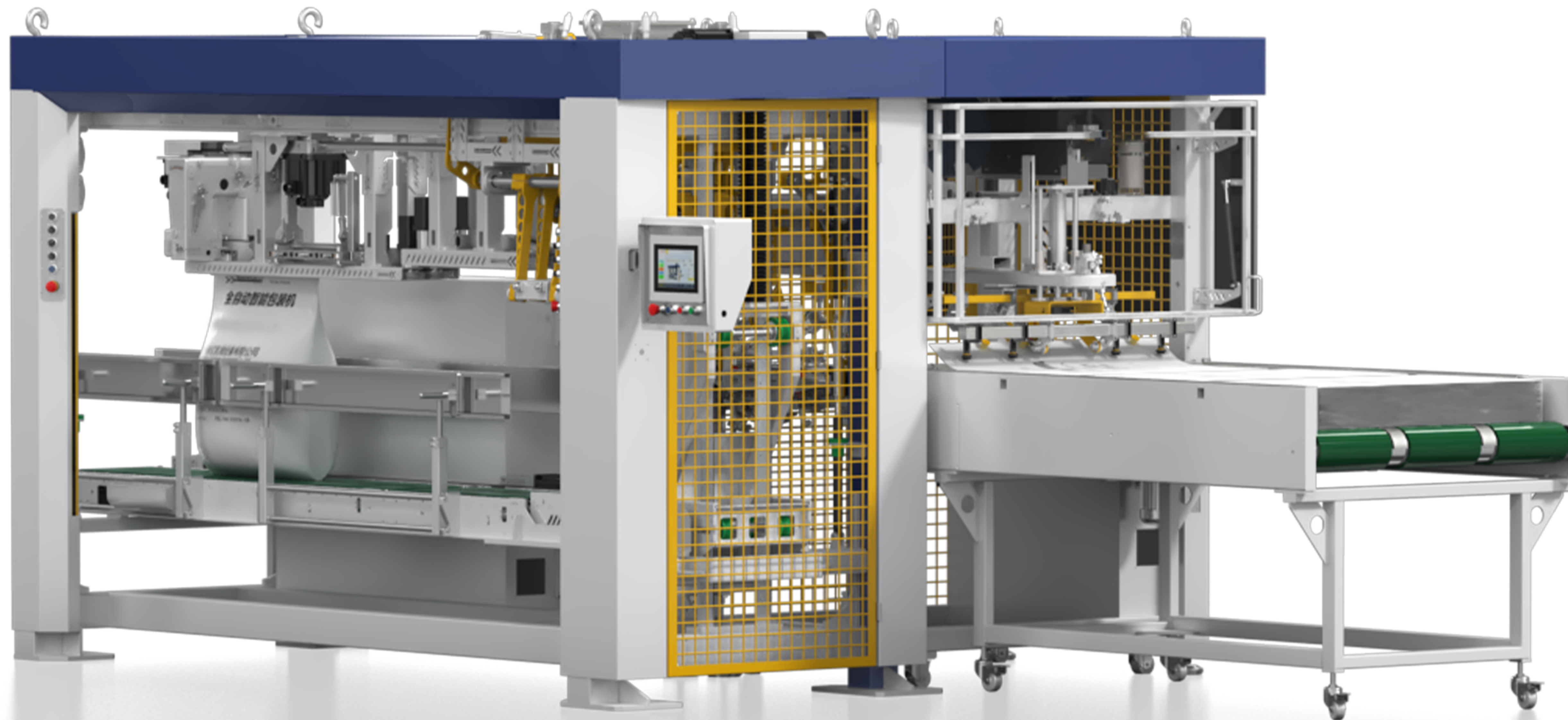

GD50

For free-flowing granules and powders

Layout Diagram

Modular design for diverse applications

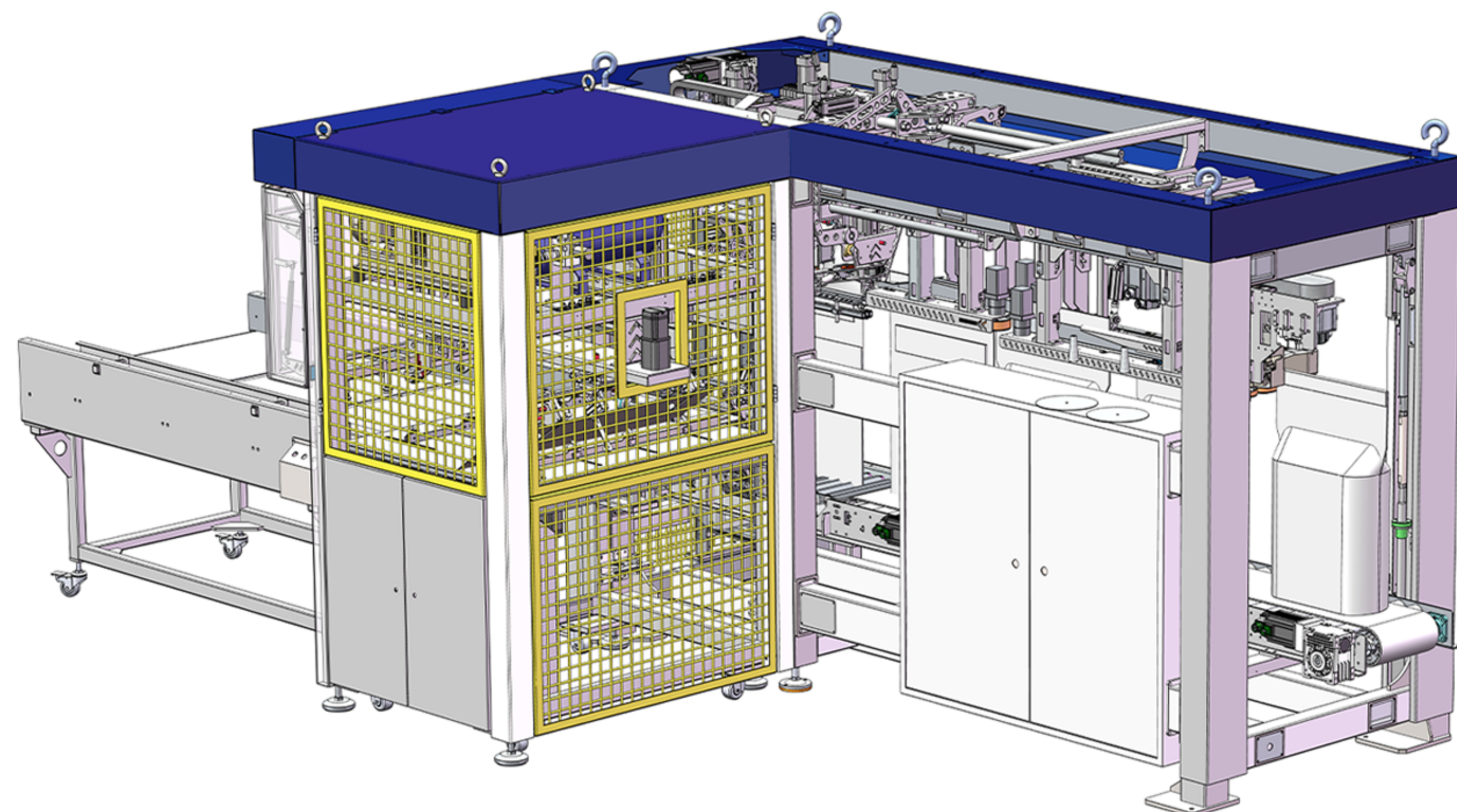
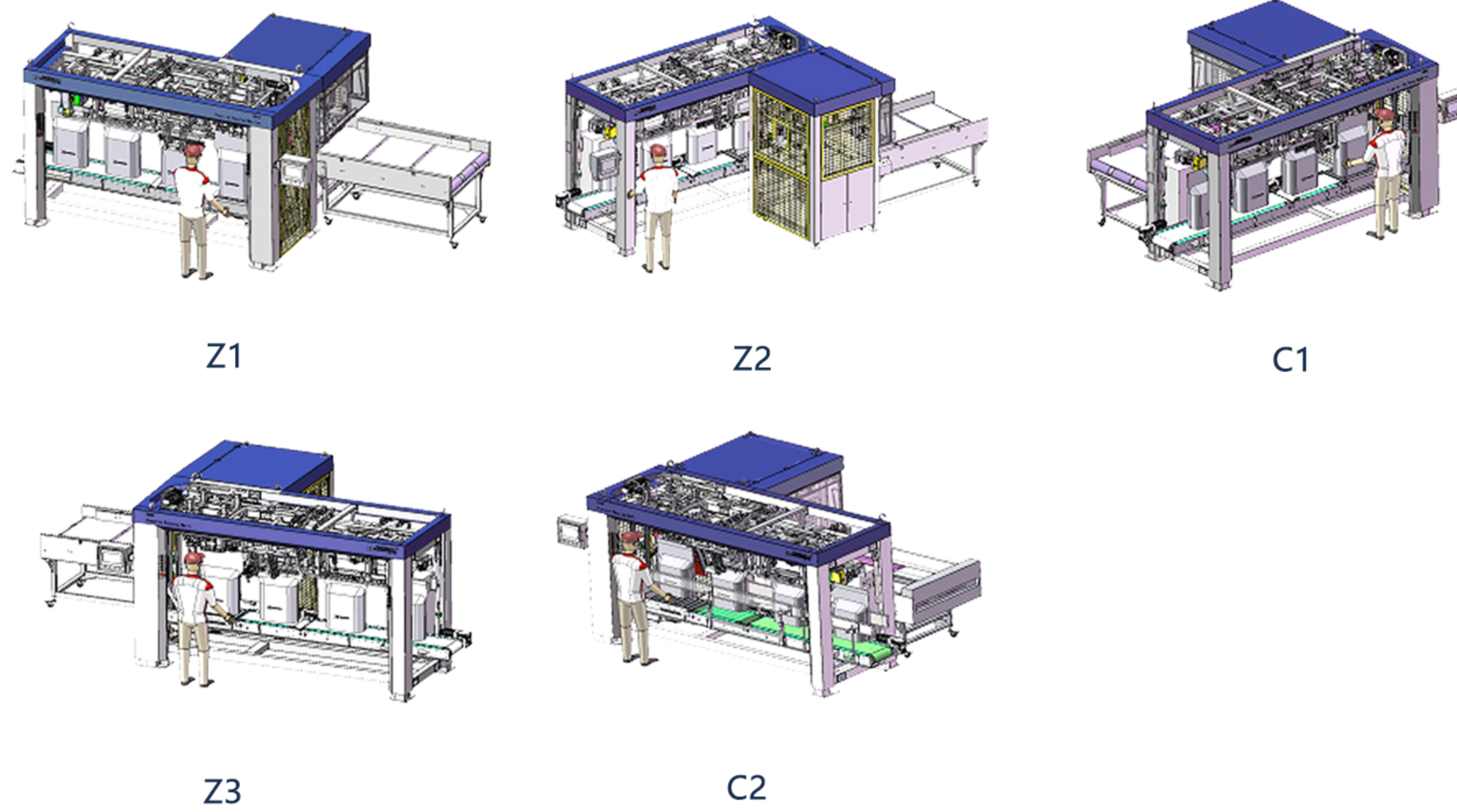

Back of Z1

Equipment Dimensions (Z1)

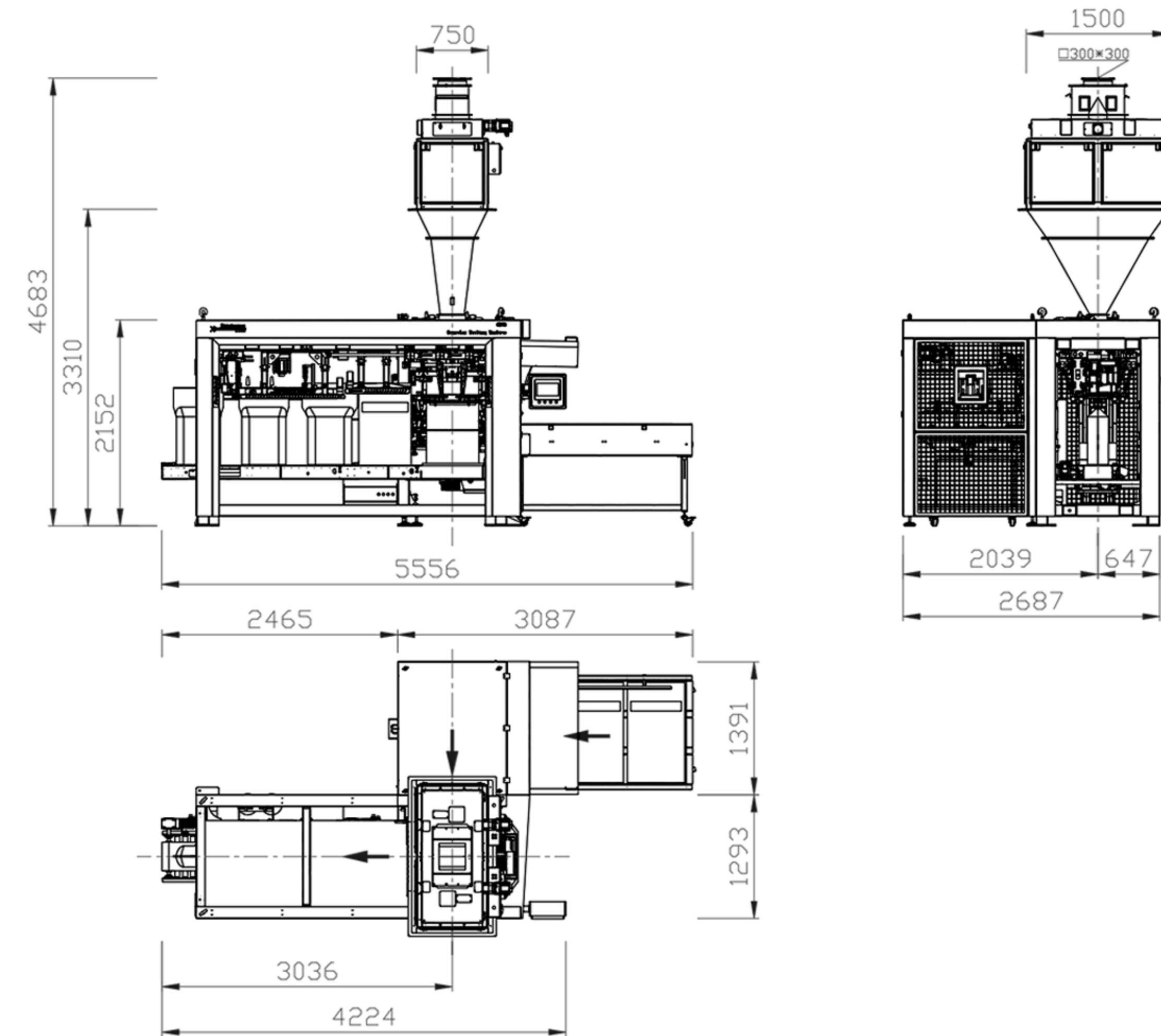

Specifications

Equipment model: GD50	Bag magazine: 150 (customizable)
Maximum speed: 1,200 Bags/hour	Voltage: AC220/380V, 50HZ
Weighing range: 25-50 kg	Total power: 10KW, 3 phase, 5 lines
Packaging accuracy: 0.2%	Compressed air: 0.6-0.8Mpa
Bag length: 850-1050mm	Gas consumption: 160Nm ³ /h
Bag width: 550-610mm	Ambient temperature: 5°-40°
Bag materials: laminated woven bags, laminated woven bags, woven bags inner with PE bags, PE bags, kraft paper bags, aluminum foil bags, etc.	

GD50 Packaging line

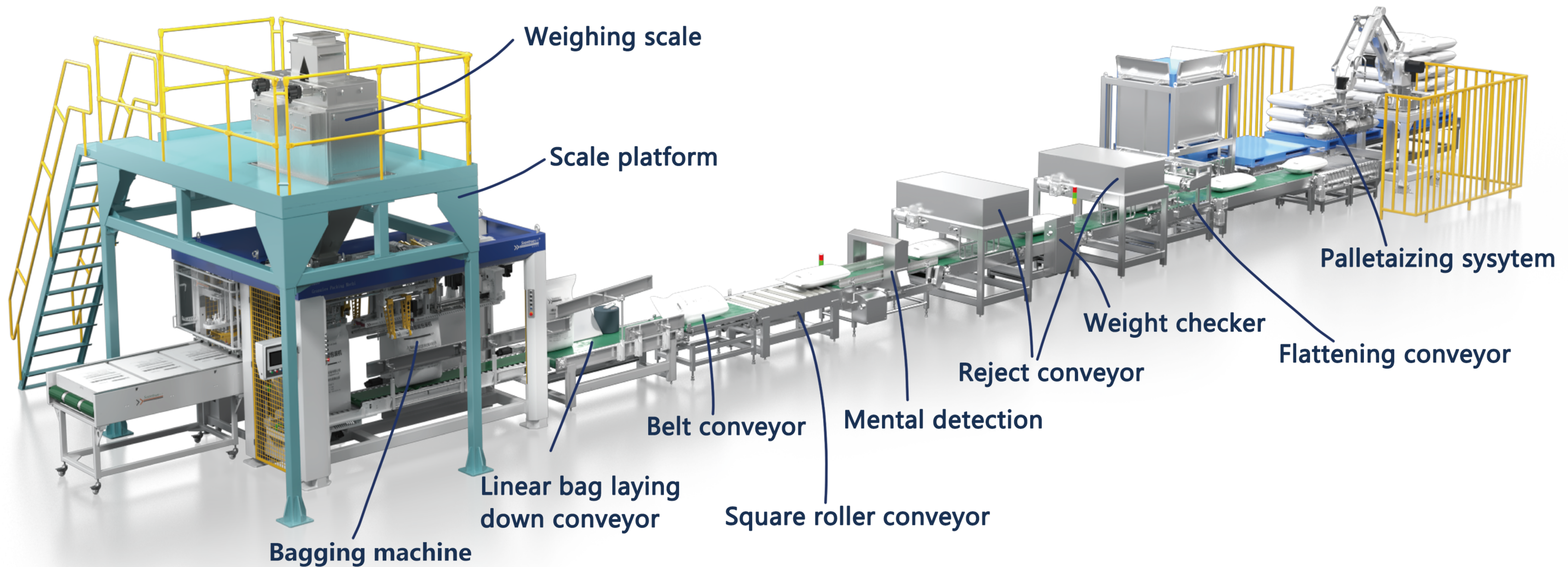

Options

Label Sewing Machine

Sew the label into the bag seam.

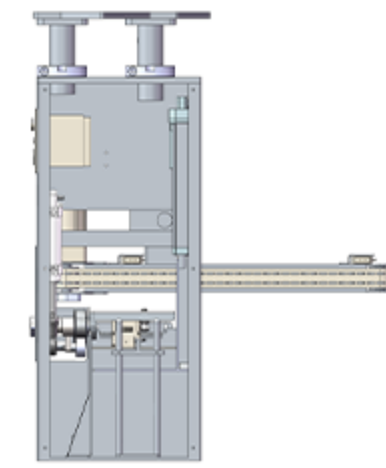

Metal Detection

Check if there is any metal in the full bag. If there is metal, it will be fed back to the rejection conveyor and removed.

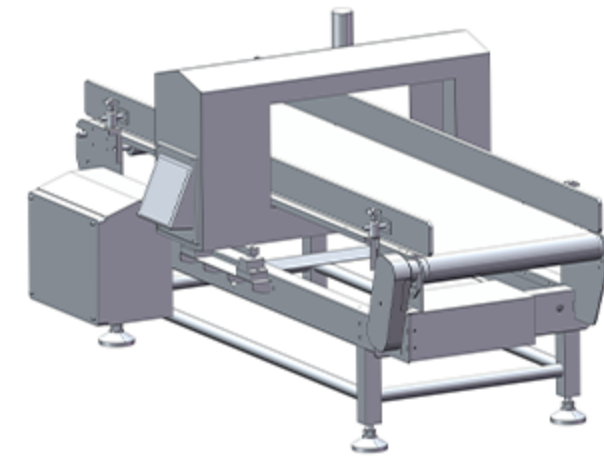

Weight Checker

Check the full bag weight. If the accuracy is insufficient, it will be fed back to the rejection conveyor and removed.

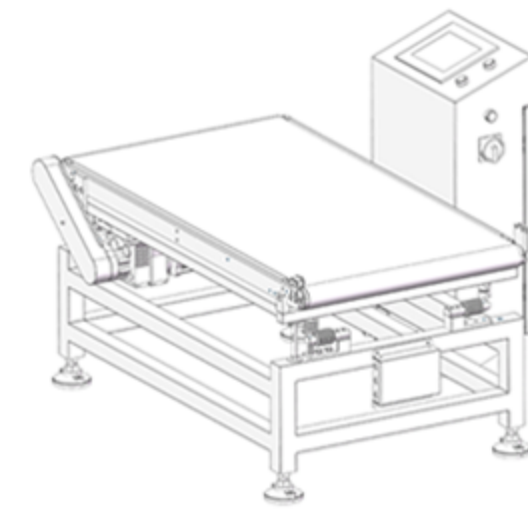

Laying Down Conveyor

Lay the bag down for the packaging line later.

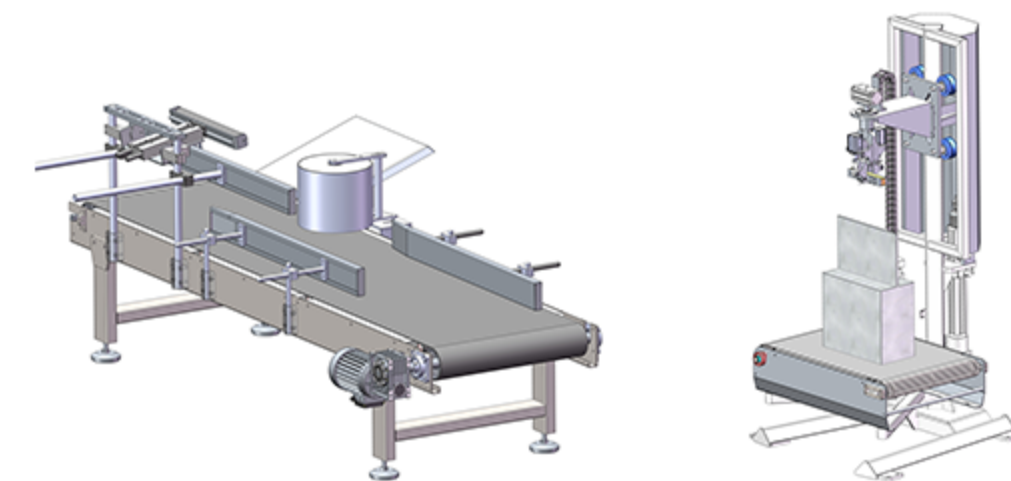

Flattening Conveyor

Compact and exhaust to solve the problems of bag swelling and palletizing.

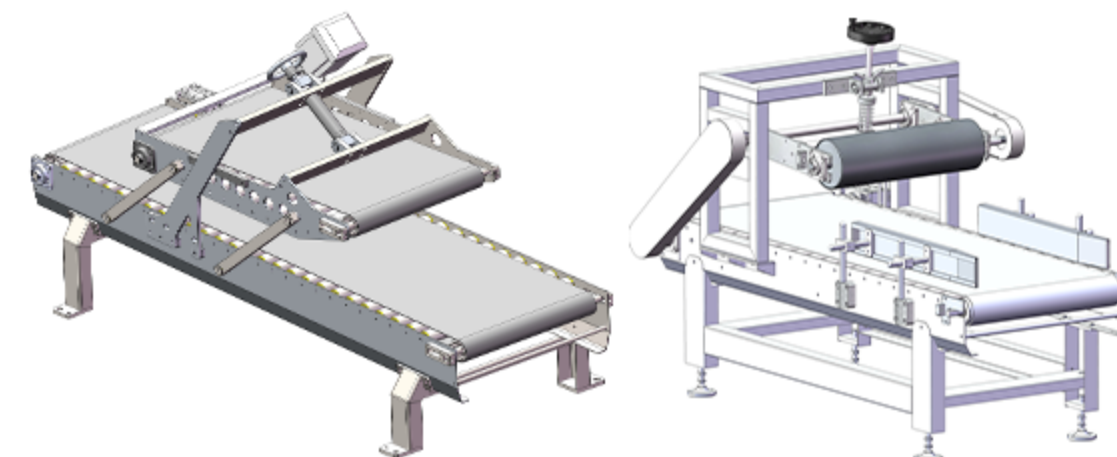

Reject Conveyor

The weight checker/metal detector sends a signal to promptly send the substandard packages to the side-inclined unpowered roller conveyor.

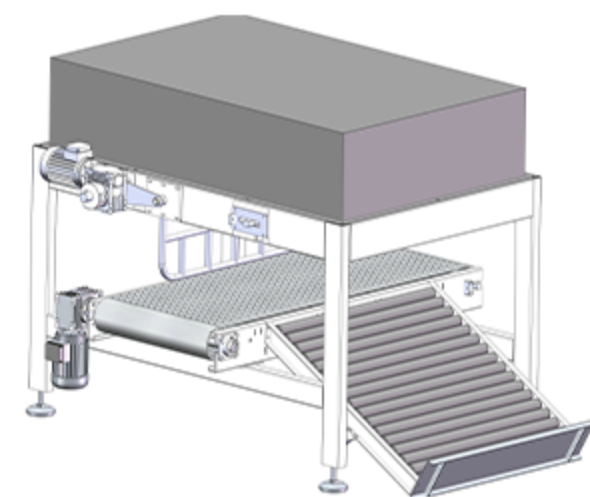

Palletizing System

Select the palletizing form as needed! Select the corresponding palletizing scheme according to different packaging speeds.

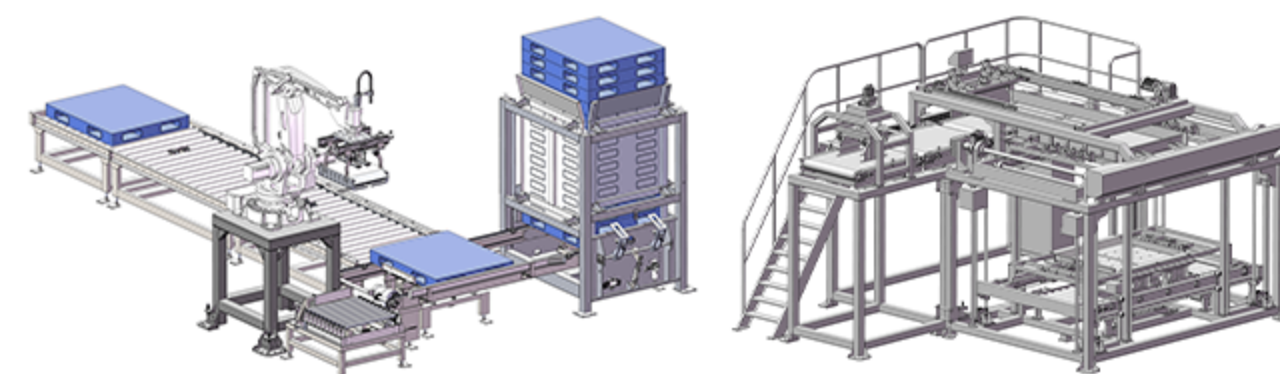

Gravity Type

Automatic loading scale

Realize the integrated operation of material quantification and bagging, significantly enhance production efficiency, and reduce errors and costs caused by manual intervention.

Parameters can be flexibly adjusted according to the material characteristics and packaging specifications to meet the production needs of multiple varieties and batches, with strong compatibility.

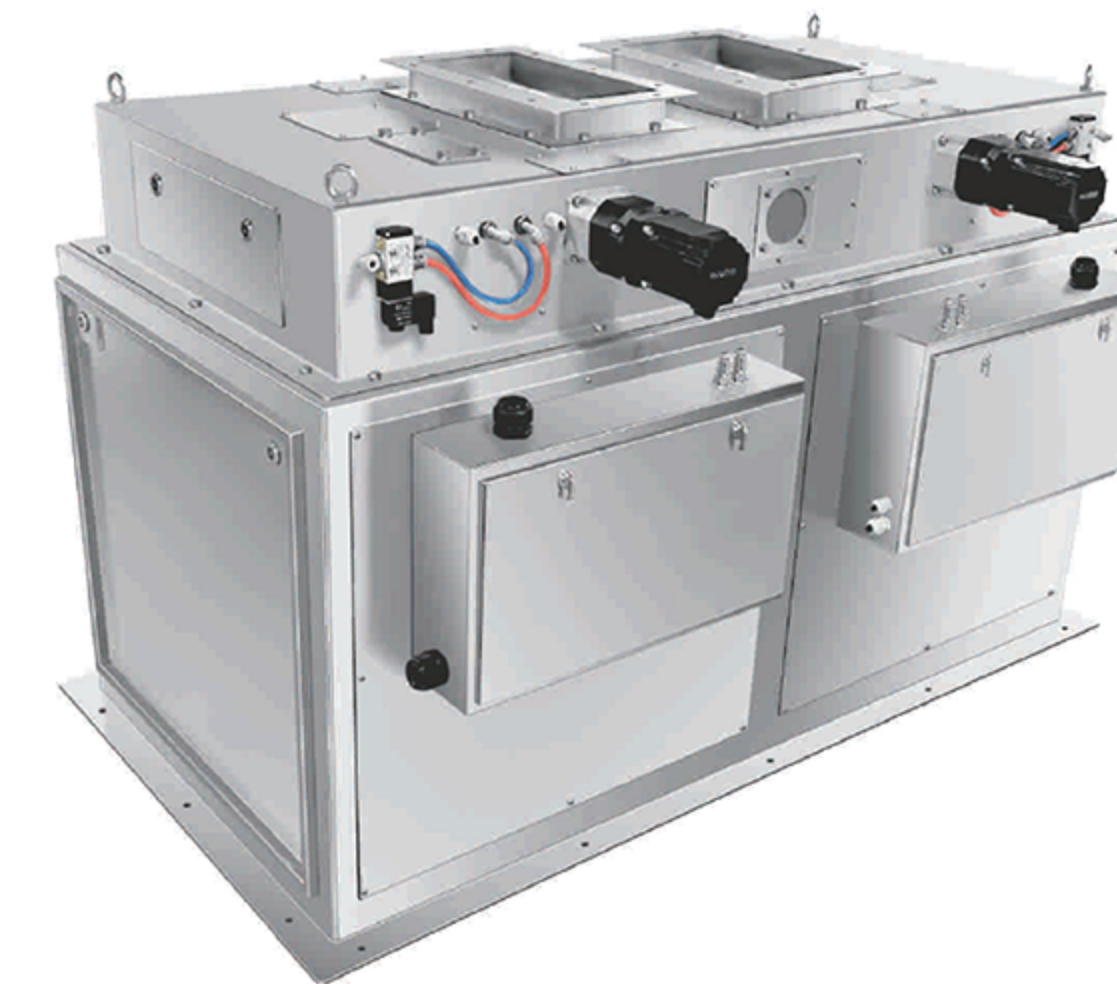

Double Servo Scale



Single Servo Sacle

Specifications

Name: Double Servo Scale

Material: SUS316/SUS304/Carbon steel

Weighing range: 25-50kg

Voltage: AC220-240V, 50/60HZ, 1KW

Display division: 1g

Communication: RS485, network port Modbus TCP/IP

Weighing accuracy: 20g

Air source: 0.4-0.6MPa

Weighing speed: ≥ 1500 packs/h

Working environment: 0-40°C

Metering hopper volume: 86Lx2

Feeding/discharging methods: Servo feeding, pneumatic discharging

SOONTRUE

Leading Packaging Solutions

Soontrue was founded in 1993 and became an benchmark in 1998. We operate four major factories in Shanghai, Foshan, Zhejiang, and Chengdu, covering a total area of 173,000 square meters.

Trusted by 20,000+ companies worldwide for reliable, high-performance automated packaging systems and tailored services.

Serving food, feed, pharma, chemicals, and new energy industries.

We deliver smarter packaging that drives efficiency up and costs down.

With a strong focus on customer satisfaction and long-term partnerships, **Soontrue** Systems and Automation remains committed to delivering customized solutions that address the unique needs of each customer.

Customer Service

Continuous customer service will either be covered directly by **Soontrue** or will occur via partners in the vicinity.

Customer Service's top priority is that customers are helped and feel they are well taken care of. This is why a promise is made to the customer when the partnership begins: **Soontrue** Customer Service will be part of the customer's team. This promise is lived, showing every customer every day that **Soontrue** Customer Service is part of their team.

An overview of all services & what makes them special

Customers worldwide trust **Soontrue** and the Customer Service Centers. China is the central contact point, but what if the customer is located in South America, North America or South Africa, for example?

The many partners around the world mean that there is always a contact partner near our customers. The expansion of the Customer Service Center will ensure that customers receive optimal care and quickly.

